

C 60

The new  
Giant.



The C 60 U -  
at home in all fields

**Tool and mould making**

Highly dynamic simultaneous  
5-axes machining up to a  
component weight of 2,500 kg

**Aerospace**

Precision in perfection

**Mechanical engineering**

Fully automatic and flexible  
manufacturing systems

**Motor sport**

Highest precision at  
high availability

**Subcontract industry**

Dynamic, precise and reliable



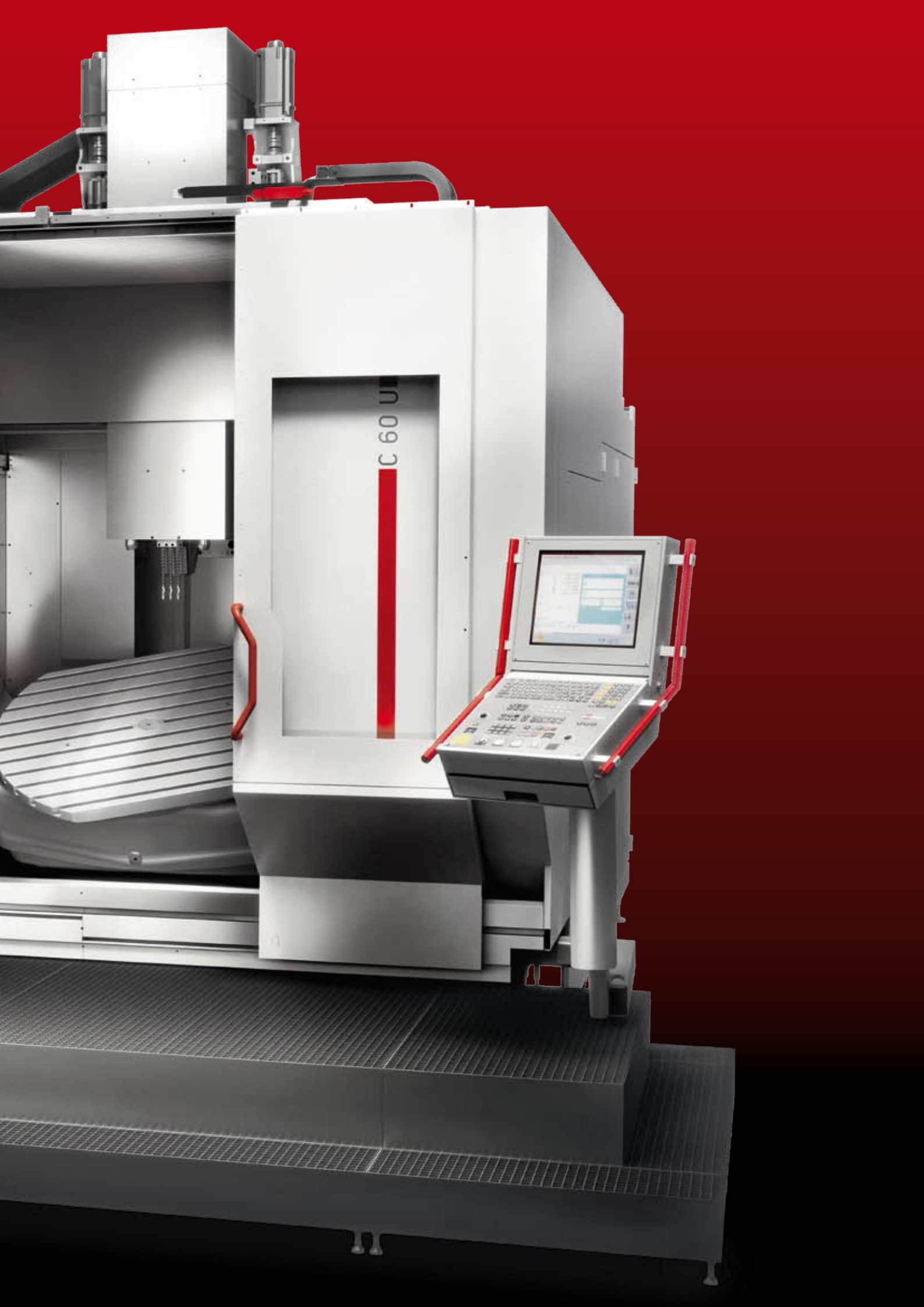

# C 60 U

5-axes / 5-sided machining  
up to 2,500 kg

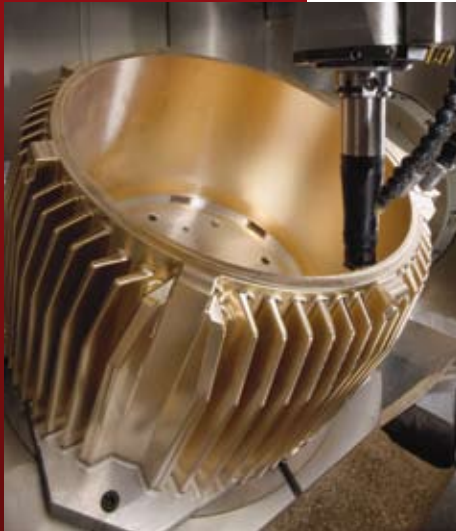

## Working area

Traverse	
X-Y-Z	1,200-1,300-900 mm
Rapid linear traverse	
X-Y-Z	50 m/min
Linear acceleration	
X-Y-Z	6 m/s <sup>2</sup>

## Main spindle drive

Speed	9,000 rpm.
Speed	10,000 rpm.
Speed	12,000 rpm.
Speed	18,000 rpm.
Max. torque	up to 476 Nm
Max. output	up to 56 kW

## Tool changer (pick up)

Magazine position	70 / 50
Chip-to-chip time*	approx 9.5 s

## Control

Heidenhain	iTNC530
Siemens	S 840 D SL

\* (chip-to-chip times in accordance with VDI 2852, sheet 1)



The (to date)  
largest  
from Hermle.

# C 60

## Dynamic in a new dimension

**3 axes in the tool**  
component independent dynamics

---

**Pick-up magazine**  
integrated in the base, thereby saving space

---

**stainless steel lining**  
of the entire working area

---

**Working area with optimised swarf ejection**  
dry machining

---

**Swivelling range**  
of the NC swivelling rotary tables  $+130^{\circ}$  to  $-130^{\circ}$

---

**Large working area**  
relative to the machine footprint

---

**Accessibility**  
very good ergonomics

---

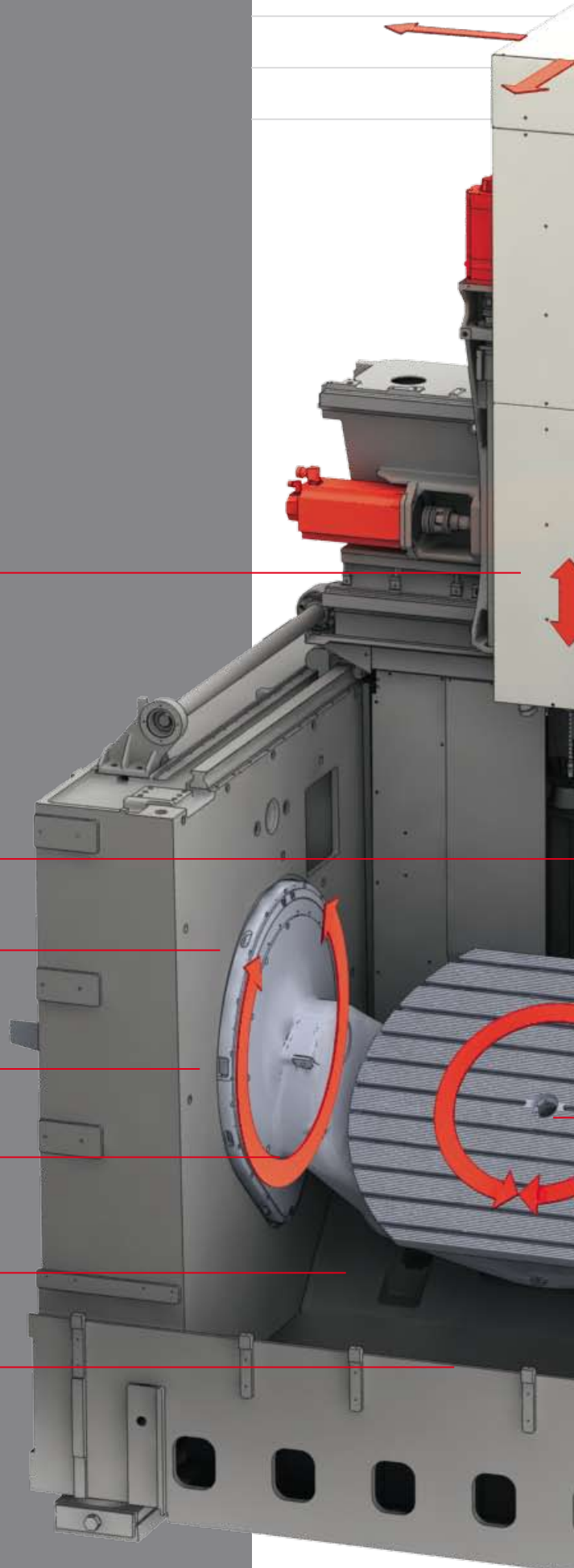

DYNAMICS

ACCURACY

COMPACTNESS

SURFACE QUALITY

AVAILABILITY

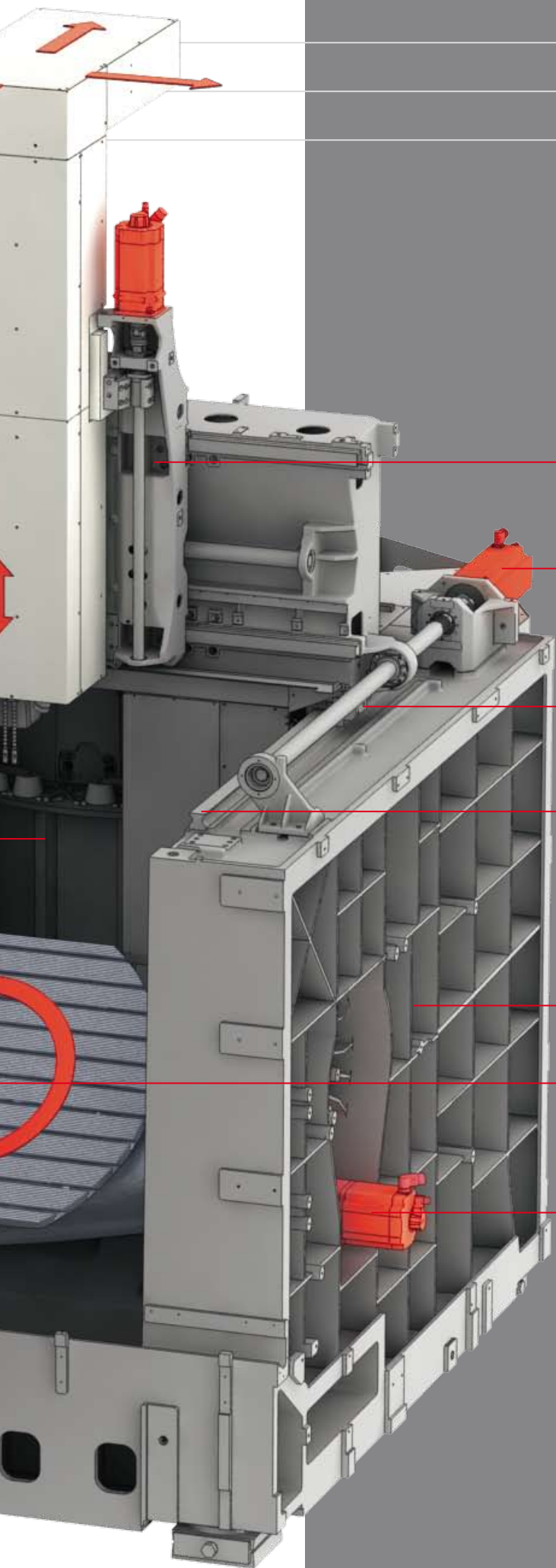

**Tandem drive (Z-axis)**  
for high machine dynamics in the Z-axis

**Tandem drive (Y-axis)**  
for high machine dynamics in the Y-axis

**Force characteristics**  
3 guideways with one guideshoe  
for ideal force balance

**Linear axes**  
above the working area

**Modified gantry design**  
with ideal main axis support

**Torquemotor (C-axis)**  
for high dynamics

**Tandem drive (A-axis)**  
avoidance of torsion and high accuracy

# Construction

## Large workpiece dimensions

Workpiece diameter max.  $\varnothing$  1200 mm / workpiece height max. 900 mm

## Coolant tank

with large coolant volume

## Central cable routing

integrated into the machine enclosure

## Encapsulated working area

with automatic top and laminated glass safety panes

## Crane loading

door opening max. 1450 mm

## Platform extending

along the entire front of the machine

## Control panel

ergonomically pivotable, height-adjustable and with tiltable 19" screen

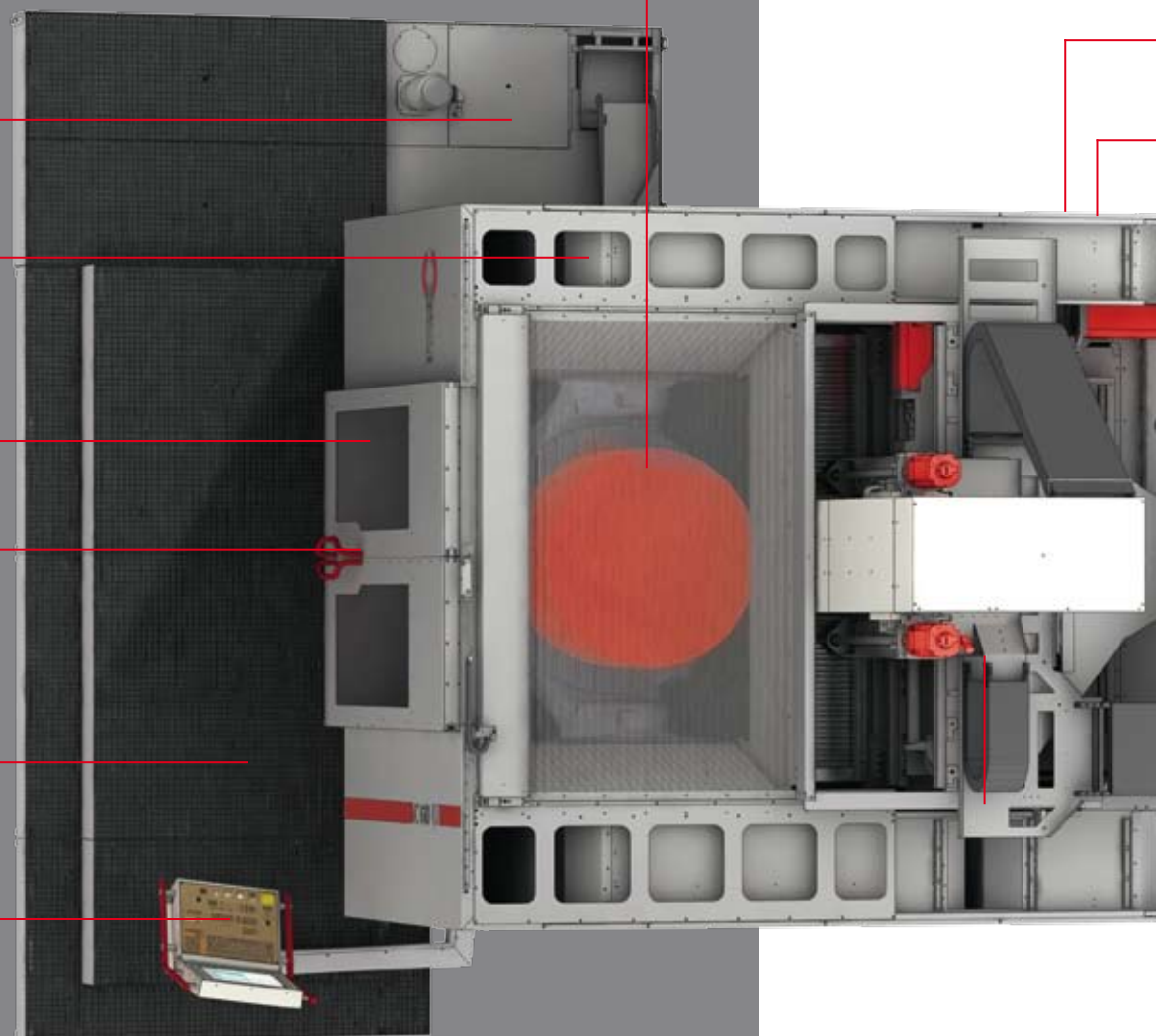

**Fluidbox**

with latest bus technology

**Service door**

for maintenance work and service activities

**Central cooling**

for the entire machine

**Magazine loading and unloading point**for ergonomic/  
ground-level tool loading**Central switch cabinet**

with air-conditioning unit

**Design principle**

- Modified gantry design
- Three axes in the tool, thus workpieces independent dynamics, ideal pre-requisite for rapid traverses and feed up to 50 m/min
- Modular configuration of the table and expansion variants in the multi-functional machine base
- Drives and guideways outside / above the working area
- Compact design, thus little space required
- Complete transport
- No foundation required
- Optimised static and dynamic properties
- Maximum utilisation, positioning and long term accuracy
- High dynamics in the machining process
- Short positioning and start times on account of high acceleration of 6 m/s<sup>2</sup>

**Drives and guideways**

- Y slide as a traverse rests on 3 carriages with 3 staggered guideways
- Tandem drives in X, Y- and Z-axes
- Good guideway ratio of the traverse which is moved by a tandem drive on both sides near the outer guides
- Roller recirculating guideways in all linear axes, thus constant dynamic conditions
- Digital AC servo motors with pretensioned ball screws
- Permanent position monitoring by absolute, optical measuring systems in all axes
- Low-maintenance automatic central grease lubrication system

**Tool change**

- Automatic tool change in cycle
- Ring magazine 70 / 50 tools as SK 40, HSK A 63, SK 50 or HSK A 100, integrated in the machine base unit
- Protected outside the work area and thus minimised risk of tools becoming soiled

**Electronics**

- Digital drives
- Absolute measuring systems
- Latest control technologies
- Frequency-based recovery of the braking energy into the mains
- Switch cabinet with air-conditioning unit



# Table variants

## What makes our table concept so special

### SWIVELLING AXIS A IN THE COMPONENT

Complicated 5-axis machining processes are carried out by comparatively small traverses of the linear axes

### VERY LARGE COLLISION CIRCLE

Optimum utilization of the working area

### TANDEM DRIVE

Torsion-free highly dynamic positioning of the swivelling axis A

### TORQUE DRIVES

Highly dynamic movements in the rotary axis

### SEPARATION OF THE ROTARY AND SWIVELLING AXES

User and programmer friendly based on easy follow-up of the table movements

### TABLE LOAD

High masses on all table variants

### NC-controlled swivelling rotary table

Clamping surface:	<b>Ø 900 mm</b>
T-grooves:	<b>parallel 13 / 18 H7</b>
Swivel range:	<b>+/- 130°</b>
Speed - swivelling axis A:	<b>15 rpm.</b>
Speed - rotary axis C:	<b>30 rpm.</b>
Type of drive axis C:	<b>torque</b>
Maximum table load:	<b>2,500 kg</b>

### NC-controlled swivelling rotary table

Clamping surface:	<b>Ø 1,350 x 1,100 mm</b>
Max. workpiece circle monitoring:	<b>Ø 1,400 mm</b>
T-grooves:	<b>parallel 11 / 22 H7</b>
Swivel range:	<b>+/- 130°</b>
Speed - swivelling axis A:	<b>15 rpm.</b>
Speed - rotary axis C:	<b>30 rpm.</b>
Type of drive axis C:	<b>torque</b>
Maximum table load:	<b>2,500 kg</b>



# Magazine

INTEGRATION INTO THE MACHINE BASE

VERY GOOD ACCESSIBILITY

ERGONOMIC LOADING AND UNLOADING POINT ON THE BACK OF THE MACHINE

LOADING HANDLING FOR THE PICK-UP MAGAZINE

COVERS FOR THE SPINDLE TAPERS

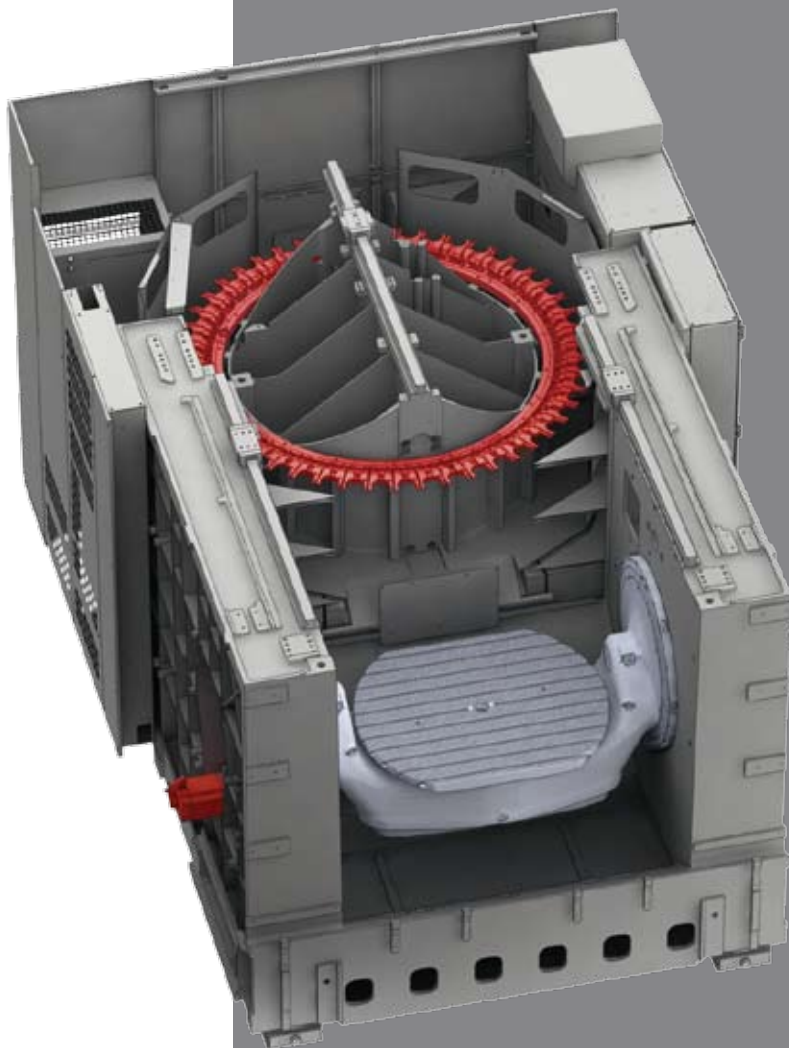

## Tool changer (pick-up)

Interface:	SK 40 / HSK A 63	SK 50 / HSK A 100
Chip-to-chip time*:	approx. 9.5 s	approx. 9.5 s
Magazine positions:	70	50
Maximum tool length:	500 mm	500 mm
Maximum tool diameter:	Ø 160 mm	Ø 250 mm
Maximum tool weight:	15 kg	30 kg
Max. full magazine load:	560 kg	550 kg

\* (chip-to-chip times in accordance with VDI 2852 sheet 1)

# Spindles

HIGH-TECH SPINDLES FOR DEMANDING MILLING PROCESSES

SLIM-END SPINDLE FOR MACHINING DEEPER CAVITIES

FEW IRREGULAR EDGES (PREVENTION OF COLLISION)

## Spindle

Spindle speed: **9,000 rpm.**

Interface: SK 50

Max. torque: 356 Nm

Max. output: 56 kW

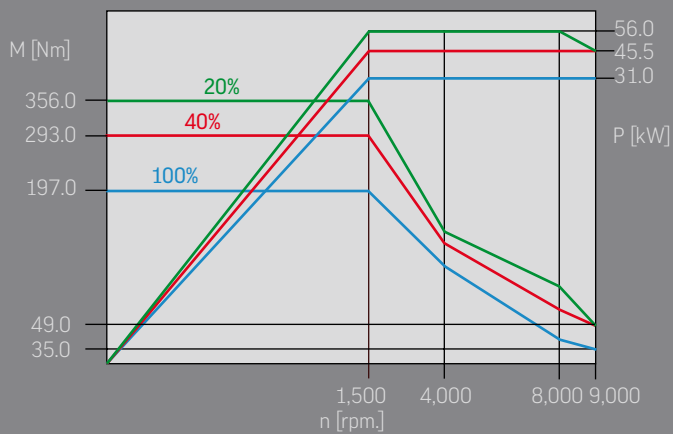

## Spindle

Spindle speed: **9,000 rpm.**

Interface: HSK A 100

Max. torque: 476 Nm

Max. output: 41 kW

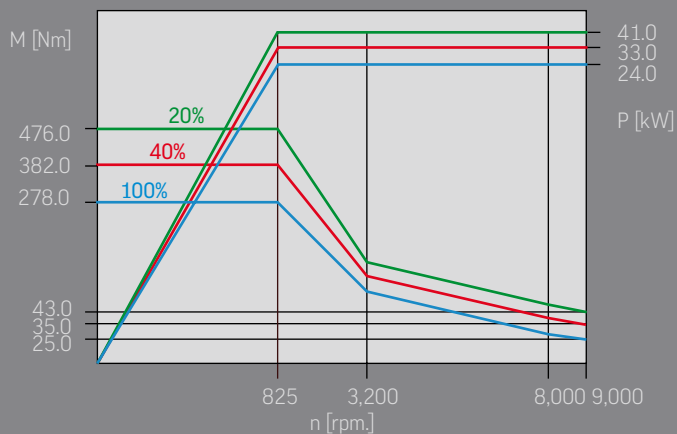

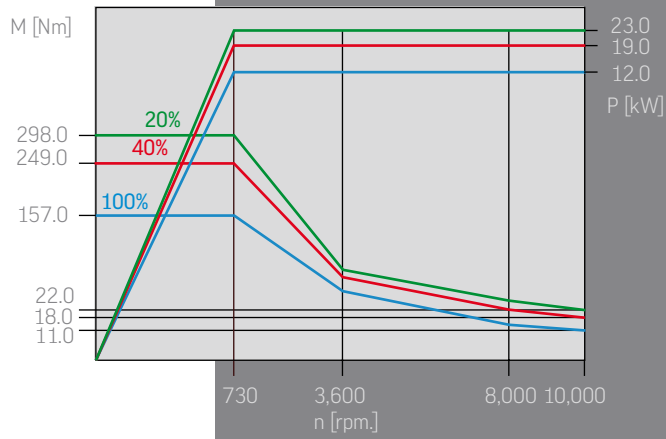

### Spindle

Spindle speed:	10,000 rpm.
Interface:	HSK A 63
Max. torque:	298 Nm
Max. output:	23 kW

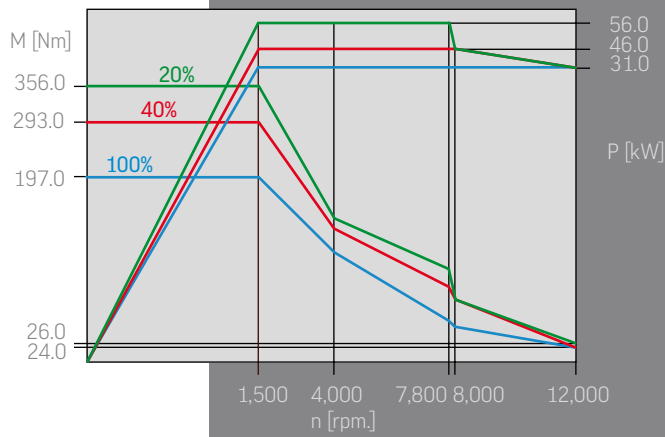

### Spindle

Spindle speed:	12,000 rpm.
Interface:	HSK A 100
Max. torque:	356 Nm
Max. output:	56 kW

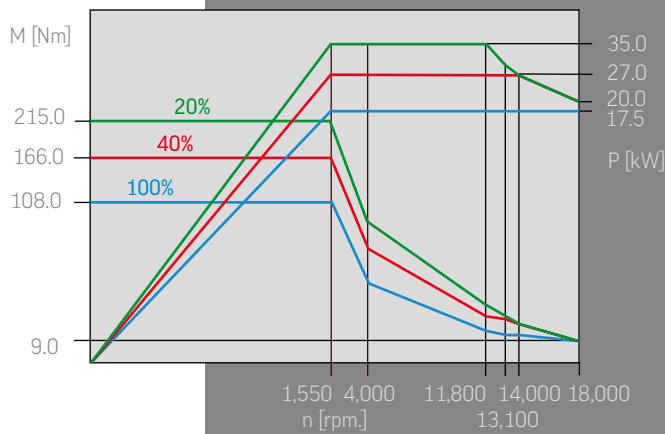

### Spindle

Spindle speed:	18,000 rpm.
Interface:	SK 40 / HSK A 63
Max. torque:	215 Nm
Max. output:	35 kW

# Controls

HEIDENHAIN iTNC 530 OR SIEMENS S 840 D SL

3D SOFTWARE

19" TFT-TECHNOLOGY

USER DEFINED SOFTKEYS

ERGONOMIC CONTROL PANEL



## CONTROLS FOR DEMANDING MILLING PROCESSES

Whether for tool and mould making, in production or in high-speed machining, they stand out for their many advantages.

## SAFE CONTROLS

Controls with integrated safety technology keeping with category 3 described in European standard EN 13849-1.

## E-MESSENGER

Increases the availability of the machines and minimises production failures.

## TELESERVICE

Teleservice ensures even faster support in case of programming and operating problems.

## FINGERPRINT

Recording of meaningful variables and evaluation of them by specialists permit preventive and forward-looking maintenance as well as efficient diagnosis in the event of a malfunction.

\* For detailed information, please refer to the individual leaflets.

# Dimensions C 60

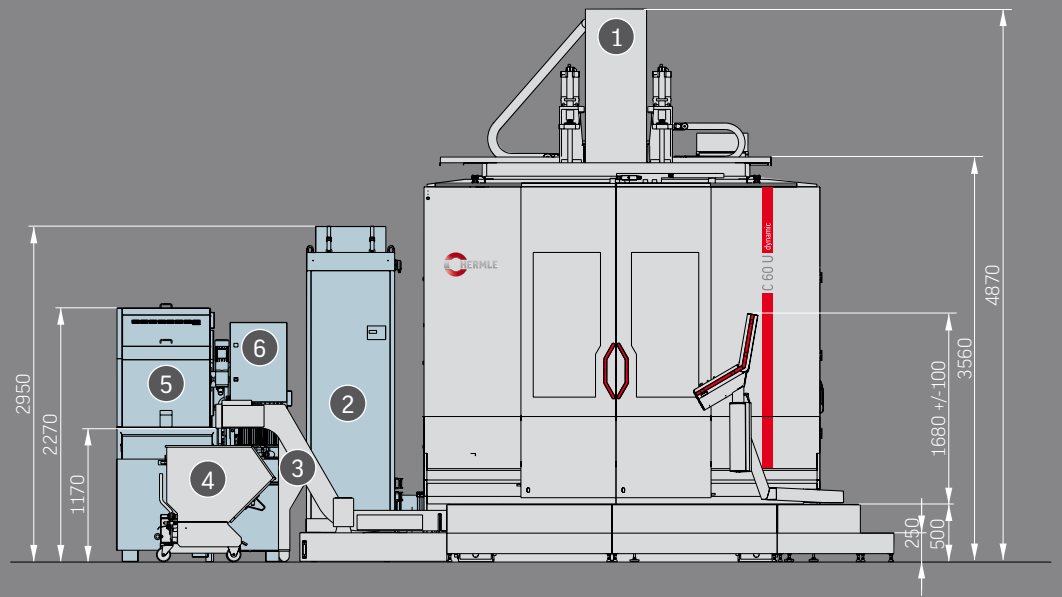

## C 60 U dynamic

- 1 Standard machine
- 2 Oil mist extractor
- 3 Chip conveyor
- 4 Chip cart
- 5 Internal coolant supply
- 6 Flow cooling unit for internal coolant supply

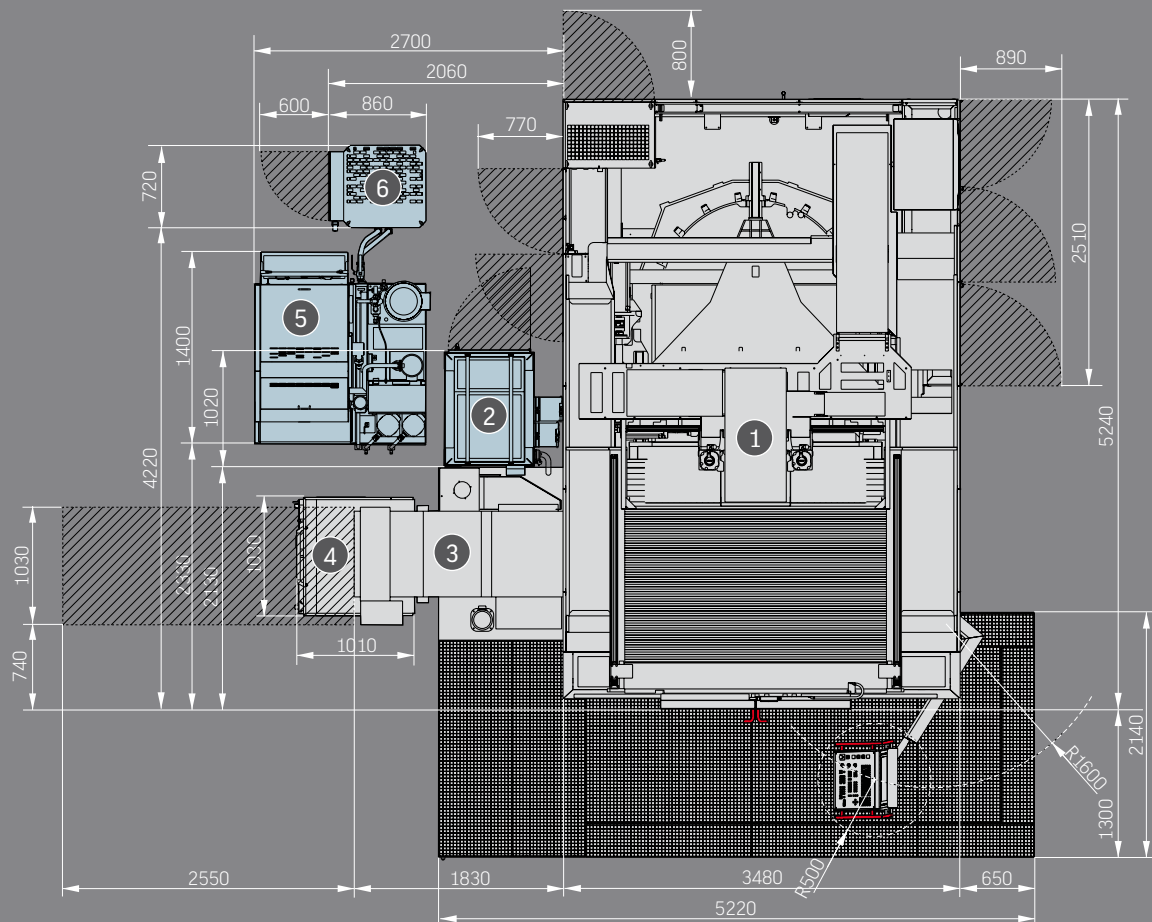

# Technical Data

Working area	Traverse	X axis	1,200 mm
	Traverse	Y axis	1,300 mm
	Traverse	Z axis	900 mm
	Linear rapid traverse	X axis	50 m/min
	Linear rapid traverse	Y axis	50 m/min
	Linear rapid traverse	Z axis	50 m/min
	Linear acceleration	X-Y-Z	6 m/s <sup>2</sup>
	Linear feed force	X axis	16000 N
	Linear feed force	Y axis	16000 N
	Linear feed force	Z axis	16000 N

Main spindle drive	Speed	18,000 rpm.	SK 40 / HSK A 63	■
	Main power / torque	20% c.d.f.	39 kW / 240 Nm	
	Speed	9,000 rpm.	SK 50	●
	Main power / torque	20% c.d.f.	60 kW / 380 Nm	
	Speed	12,000 rpm.	HSK A 100	●
	Main power / torque	20% c.d.f.	60 kW / 380 Nm	
	Speed	10,000 rpm.	HSK A 63	●
	Main power / torque	20% c.d.f.	23 kW / 298 Nm	
	Speed	9,000 rpm.	HSK A 100	●
	Main power / torque	20% c.d.f.	41 kW / 476 Nm	

Control unit	Heidenhain	iTNC 530	■
	Siemens	Sinumerik 840 D sl	■

Tool changer (pick up)	Interface	SK 40/HSK A 63	SK 50/HSK A 100	●
	Magazine pockets	70	50	
	Chip-to-chip time*	approx. 9.5 s	approx. 9.5 s	
	*(chip-to-chip times in accordance with VDI 2852 sheet 1)			
	Maximum tool length	500 mm	500 mm	
	Maximum tool weight	15 kg	30 kg	
	Maximum tool diameter	Ø 160 mm	Ø 250 mm	
	Max. full magazine load	560 kg	550 kg	

Connection-values (machine)	Mains connection	400 V / 50 Hz	400 V / 50 Hz
	Power consumption	71 kVA	84 kVA
	Compressed air	6 bar	6 bar

Weight	(Standard version)	approx. 30.0 t
--------	--------------------	----------------

Transport dimensions C 60 (basic machine)	Width	3,500 mm
	Depth	5,600 mm
	Height	4,870 mm

Hermle AG reserves the right to carry out modifications without prior notification, which may lead to deviating technical data.

Table variants	NC-controlled swivelling rotary table	Ø 900 ●	Ø 1350 ●
	Clamping surface	Ø 900 mm	Ø 1350 mm
	Clamping surface flattened on 2 sides	-	1100 mm
	Swivel range	+ 130° / - 130°	+ 130° / - 130°
	Speed - swivelling axis A	15 rpm.	15 rpm.
	Speed - rotary axis C	30 rpm.	30 rpm.
	Maximum table load	2,500 kg	2,500 kg
	T-grooves parallel	13 / 18H7	11 / 22H7

Position measuring system direct	Resolution	0.0001 mm	■
----------------------------------	------------	-----------	---

Position tolerance	Tp in X-Y-Z-axis keeping with German standard VDI/DGQ 3441 (determined at 20° Celsius +/- 1° Celsius constant ambient temperature. Our products are subject to German export laws and exports have to be approved as the achievable accuracy may be smaller / equal than 6 µm.)	0.008 mm	■
--------------------	--	----------	---

Coolant system	Amount of coolant	420 l	■
	Pump performance	5 bar / 80 L/min	

Internal coolant supply with paper tape filter	Amount of coolant	1,500 l	●
	Pressure (infinitely variable manuel)	max. 80 bar / 26 l/min	
	Mains connection	400 V / 50 Hz	
	Power consumption	26 kVA	

Chip conveyor	Scraper belt		■
	Hinged belt conveyor		●
	Ejection height of chip conveyor	1,100 mm	
	Chip cart	450 l	●

Hydraulic system	Operating pressure	120 bar	■
------------------	--------------------	---------	---

Central lubrication system	Minimum quantity lubrication		■
----------------------------	------------------------------	--	---

#### Options

Automatic cabin door	●
Rotating clear-view window	●
Electrical heat compensation	●
Electrical hand-held control module	●
Touch probe including preparation	●
Preparation for touch probe	●
Tool breakage monitoring / measuring system	●
Coolant nozzle	●
Minimal quantity lubrication internal + external	●
Air blast through the spindle centre	●
Bed flushing	●
BDE signal	●
Oil mist extractor	●
Air purge for linear scales	●
Status lamp	●

■ standard equipment

● to order

# Hermle

all over the world

## GERMANY

Hermle + Partner Vertriebs GmbH  
Phone +49 (0)7426 95-0 info@hermle-hpv.de  
Fax +49 (0)7426 95-6109 www.hermle-partner-vertrieb.de

Hermle-Leibinger Systemtechnik GmbH  
Phone +49 (0)7461 96628-0 info.hls@hermle.de  
Fax +49 (0)7461 96628-398

Hermle Maschinenbau GmbH  
Phone +49 (0)89 6735950-0 info@hermle.de  
Fax +49 (0)89 6735950-11 www.hermle.de

Hermle Demo Centre Kassel-Lohfelden  
Phone +49 (0)561 5103879 awt.kassel@hermle.de  
Fax +49 (0)561 5103889

## SWITZERLAND

Hermle (Schweiz) AG  
Phone +41 (0)52 67400-40 info@hermle-schweiz.ch  
Fax +41 (0)52 67400-41 www.hermle-schweiz.ch

Hermle WWE AG  
Phone +41 (0)41 768 51-51 info@hermle-wwe.com  
Fax +41 (0)41 768 51-50

## AUSTRIA

Hermle Österreich  
Rudolf Fluch  
Phone +43 (0)3842 83377 rudolf.fluch@hermle.co.at  
Fax +43 (0)3842 82410

Florian König  
Phone +43 (0)5244 62373 florian.koenig@hermle.co.at  
Fax +43 (0)5244 62378

## ITALY

Hermle Italia S.r.l.  
Phone +39 02 95327-241 info@hermle-italia.it  
Fax +39 02 95327-243 www.hermle-italia.it

## NETHERLANDS

Hermle Nederland B.V.  
Phone +31 (0)77 3961761 info@hermle-nederland.nl  
Fax +31 (0)77 4641070 www.hermle-nederland.nl

## BELGIUM

Sales Office Belgium  
Phone +32 (0)13 5563-83 hermle@scarlet.be  
Fax +32 (0)13 5563-84

## DENMARK

Hermle Nordic  
Phone +45 (0) 66 17 69 50 info@hermle-nordic.dk  
Fax +45 (0) 66 17 61 09 www.hermle-nordic.dk

## BULGARIA

Hermle Southeast Europe  
Phone +359 2 958 59 01 info@hermle.bg  
Fax +359 2 859 83 99

## CZECH REPUBLIC

Hermle Česká Republika  
Miloš Branda  
Phone +420 272 652 340 milos.branda@hermle.cz  
Fax +420 272 652 977

Martin Skukálek  
Phone +421 326 523 048 martin.skukalek.hpv@stonline.sk  
Fax +421 326 523 050

## USA

Hermle Machine Co. LLC  
Phone +1 414 421-9770 info@hermlemachine.com  
Fax +1 414 421-9771 www.hermlemachine.com

## CHINA

Hermle China  
Shanghai Representative Office  
Phone +86 21 2281 9188 hermlesha@126.com  
Fax +86 21 6427 1887

Beijing Representative Office  
Phone +86 10 5822 0951/2/3 hermlebeijing@vip.163.com  
Fax +86 10 5822 1426

## RUSSIA

OOO Hermle Vostok  
Representative Office of Hermle WWE AG  
Moscow  
Phone +7 495 221 83 68 info@hermle-vostok.ru  
Fax: +7 495 221 83 93 www.hermle-vostok.ru

Representative Office of Hermle WWE AG  
St. Petersburg,  
Phone +7 812 702 67 32 spb@hermle-wwe.com  
Fax: +7 812 702 67 33

Representative Office of Hermle WWE AG  
Togliatti  
Phone +7 8482 51 76 48 tlt@hermle-wwe.com  
Fax: +7 8482 51 76 47

The machining examples used in this leaflet are published with the explicit approval of our friendly customers.

The information in this leaflet only contains general descriptions or performance characteristics which in a real application do not always meet the description or which may change by further development of the products.

The requested performance parameters shall be binding only, if they are explicitly agreed within the sales contract.



Maschinenfabrik  
Berthold Hermle AG  
Industriestraße 8-12  
D-78559 Gosheim  
Phone +49 (0)7426 95-0  
Fax +49 (0)7426 95-6109  
info@hermle.de  
www.hermle.de