

# C 50

The Powerful



# C 50

5-axes / 5-sided machining  
up to 2,000 kg

The C 50 U –  
at home in all fields

**Tool and mould making**

Highly dynamic simultaneous  
5-axes machining up to  
a component weight of  
2,000 kg.

**Medical engineering**

Difficult to machine material –  
in record time

**Aerospace**

Precision in perfection

**Mechanical engineering**

Fully automatic and flexible ma-  
nufacturing systems

**Motor sport**

Highest precision at  
high availability

**Subcontract industry**

Dynamic, precise and reliable



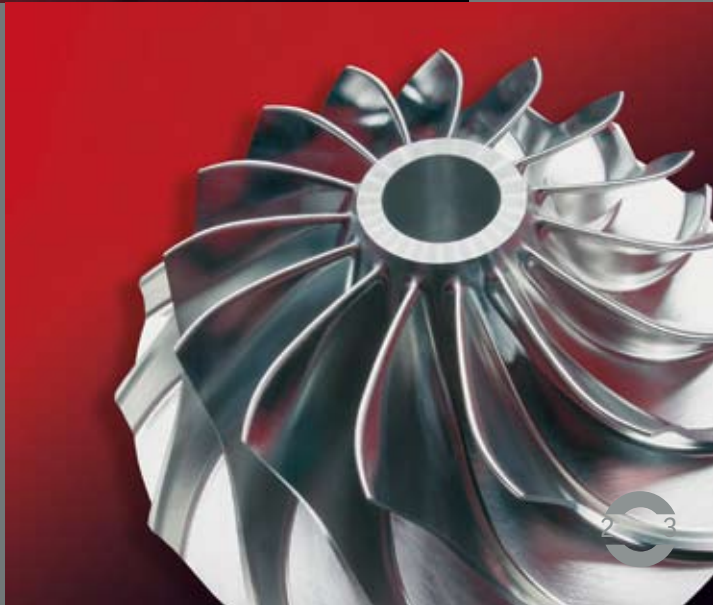
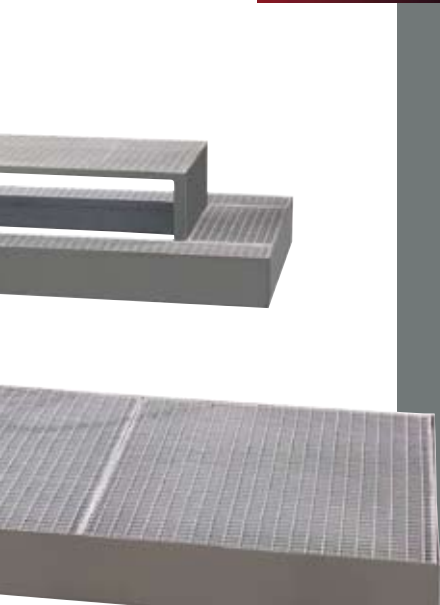

# C 50

Dynamic in a  
new dimension

**3 axes in the tool**  
component independent dynamics

**Pick up magazine**  
integrated in the base, thereby saving space

**Stainless steel design**  
of the entire working area

**Ideal chip clearance**  
dry machining

**Swivel range**  
of NC swivel rotary tables  $+100^{\circ}$  to  $-130^{\circ}$

**Large working area**  
relative to the machine footprint

**Accessibility**  
very good ergonomics

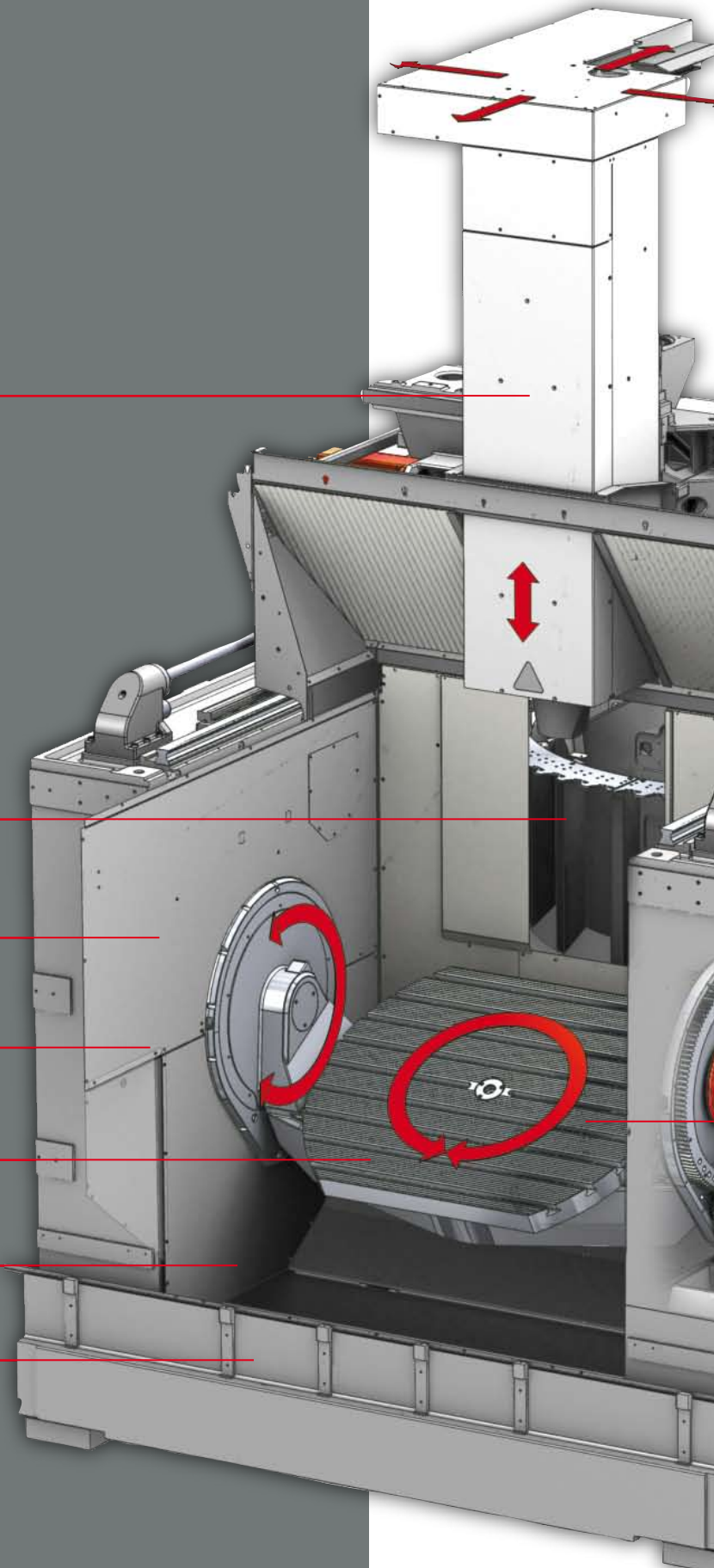

DYNAMICS

ACCURACY

COMPACTNESS

SURFACE QUALITY

AVAILABILITY

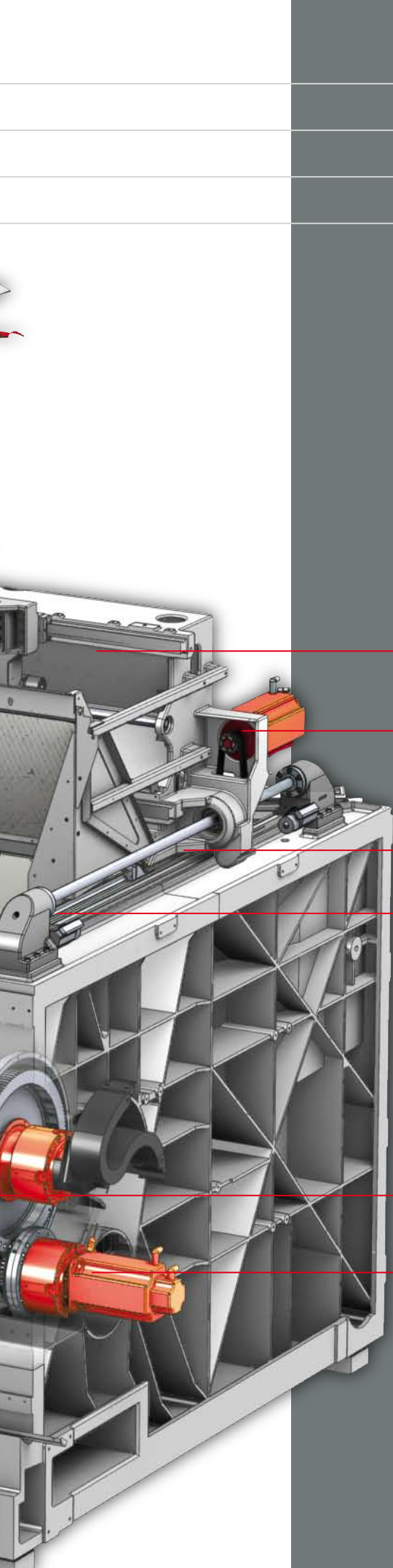

**Modified gantry design**  
with ideal main axis support

**Tandem drive**  
for high machine dynamics in the Y-axis

**Force characteristics**  
three guideways with one guideshoe  
for ideal force balance

**Linear axes**  
above the working area

**Torque motor (C-axis)**  
for high dynamics

**Tandem drive (A-axis)**  
prevents torsion with high accuracy

# Construction

## Large tool dimensions

max. tool diameter  $\varnothing 1000$  mm / max. tool height 810 mm

## Coolant tank

with large coolant volume

## Central cable routing

integrated into the machine enclosure

## Encapsulated working area

with autom. top and laminated safety glass panes

## Crane loading

max. door opening 1250 mm

## Control panel

ergonomic rotating

## Platform

extending along the entire front of the machine

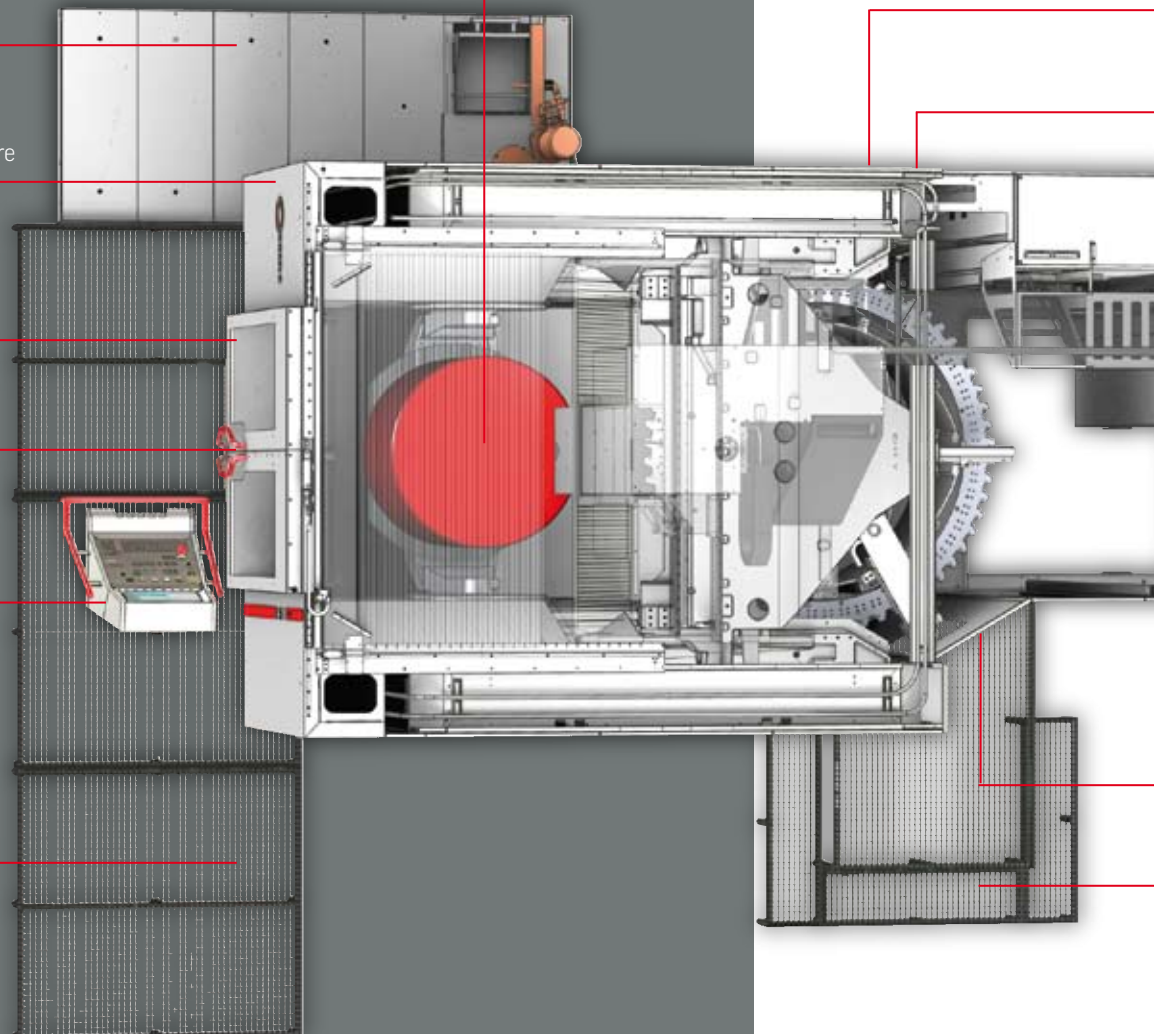

**Cube 67**

most modern Profibus technology

**Service door**

for maintenance work - pneumatic/lubrication

**Switch cabinet**

central with cooling unit

**Cooling**

central for the entire machine

**Service door**

for maintenance work-hydraulic

**Magazine loading and unloading station**

for ergonomic tool loading

**Platform**

for magazine loading and unloading station

**Design principle**

- Modified gantry design, the disadvantages of the conventional gantry design have been avoided
- Three axes in the tool, thus workpieces independent dynamics, ideal pre-requisite for rapid traverses and feed up to 60 m/min.
- Modular configuration of the table and expansion variants in the multi-functional machine base
- Drives and guideways outside / above the working area
- Z axis with electrical and mechanical quick stop against uncontrolled drop
- Compact design, thus little space required
- Complete transport
- No foundation required
- Optimised static and dynamic properties
- Maximum utilisation, positioning and long term accuracy
- High dynamics in the machining process
- Short positioning and start times on account of high acceleration of 6 m/s<sup>2</sup>

**Drives and guideways**

- Y slide as a traverse rests on three carriages with three staggered guideways
- Good guidance ratio of the cross slide which is moved by tandem drives on both sides close to the lateral guideways
- Very rigid dynamic cross slide rest
- Roller recirculating guideways in all linear axes, thus constant dynamic conditions
- Digital AC servo motors with pretensioned ball screws
- Permanent position monitoring system
- Low-maintenance automatic central grease lubrication system

**Tool change**

- Automatic tool change in cycle
- Ring magazine for 60 / 42 tools as SK 40, HSK A 63, SK 50 or HSK A 100
- Integrated in the machine base unit
- Protected outside of the working area, thus no contamination of the tools

**Electronics**

- Digital drives
- Absolute measuring systems
- Latest control technologies
- Frequency-based recovery of the braking energy into the mains
- Switch cabinet with air-conditioning unit

# Machine

ADVANTAGES OF A UNIQUE MACHINE CONCEPT

LARGEST WORKING AREA RELATIVE TO THE INSTALLATION SURFACE

UNIQUE AXIS CONCEPT

SHORT CHIP-TO-CHIP TIMES ON ACCOUNT OF INTEGRATED TOOL MAGAZINE

SINGLE LIFT TRANSPORT AND BOLT FREE INSTALLATION

CONSISTENT MODULAR DESIGN FROM THE STANDARD MACHINE  
TO THE FLEXIBLE MACHINING CENTRE





#### Working area

Traverse	
X-Y-Z	1,000-1,100-750 mm
Rapid linear traverse	
X-Y-Z	60-60-55 m/min
Linear acceleration	
X-Y-Z	6 m/s <sup>2</sup>

#### Main spindle drive

Speed	18,000 rpm.
Torque	up to 240 Nm
Main power	up to 39 kW
Speed	9,000/12,000 rpm.
Torque	up to 380 Nm
Main power	up to 60 kW

#### Tool changer (pick up)

Magazine positions	60 / 42
Chip-to-chip time	approx. 7,0 s

#### Control

Heidenhain	iTNC 530
Siemens	S 840 D

\*(chip-to chip times were determined in accordance with VDI 2852, sheet 1 in a 3-axis design)

# Table variants

HIGH DEGREES OF FREEDOM IN THE WORKING AREA

VERY HIGH TABLE LOAD (UP TO 2,000 KG AT HIGHEST PRECISION)

NO CHIP COLLECTION ON THE TABLE (TABLE SWIVELLING)

SWIVELLING AXIS A AND ROTARY AXIS C ARE IN THE WORKPIECE (U SHAPE)

TORSION PREVENTION THROUGH TANDEM DRIVES

HIGH DYNAMICS THROUGH LINEAR TECHNOLOGY  
(HIGH-TORQUE MOTORS IN THE ROTARY AXIS)

WIDE TRUNNION SUPPORT DISPLACEMENT RESULTS  
IN A LARGE COLLISION FREE CIRCLE

SWIVELLING AXIS A IN THE COMPONENT

Complicated 5-axis machining processes are carried out by comparatively small traverses of the linear axes

VERY LARGE COLLISION CIRCLE

Optimum utilization of the working area

SEPARATION OF THE ROTARY AND SWIVELLING AXES

User and programmer friendly based on easy follow-up of the table movements

TABLE LOAD

High masses on all table variants

MEDIA SUPPLY

For nine supply lines (option)

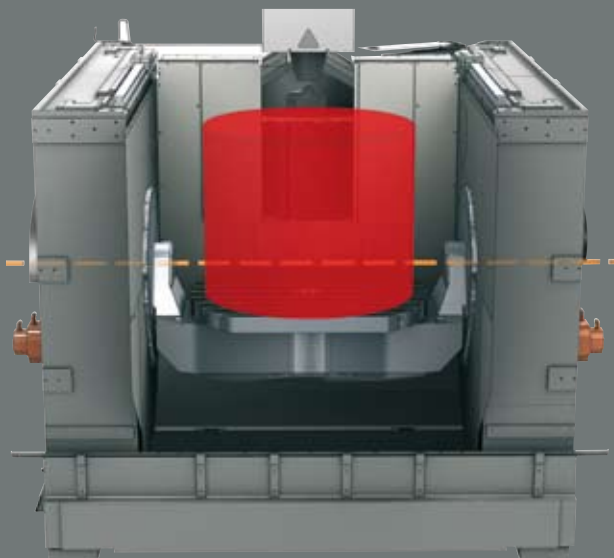

### NC-controlled swivelling rotary table

Clamping surface:	Ø 1150 mm
2 sided flattened to:	900 mm
Swivel range:	+ 100° / - 130°
Speed - swivelling axis A:	20 rpm.
Speed - rotary axis C:	30 rpm.
Type of drive axis C:	Torque
Maximum table load:	2.000 kg
T-grooves:	parallel 9 / 18 H7

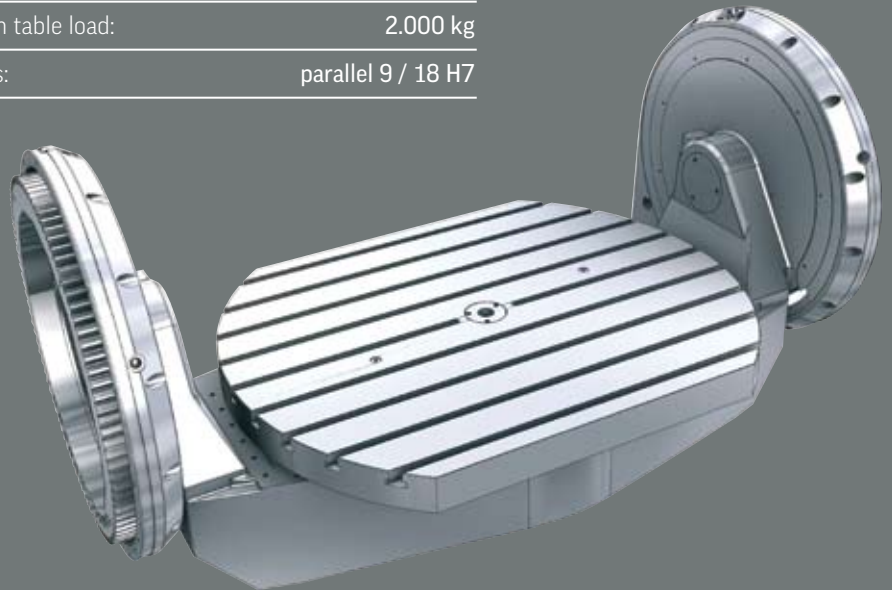

### NC-controlled swivelling rotary table

Clamping surface:	Ø 700 mm
Swivel range:	+ 100° / - 130°
Speed - swivelling axis A:	20 rpm.
Speed - rotary axis C:	30 rpm.
Type of drive axis C:	Torque
Maximum table load:	2.000 kg
T-grooves:	parallel 9 / 14 H7
Adjacent clamping plate (Option)	1200 x 700 mm
T-grooves:	parallel 11 / 14 H7

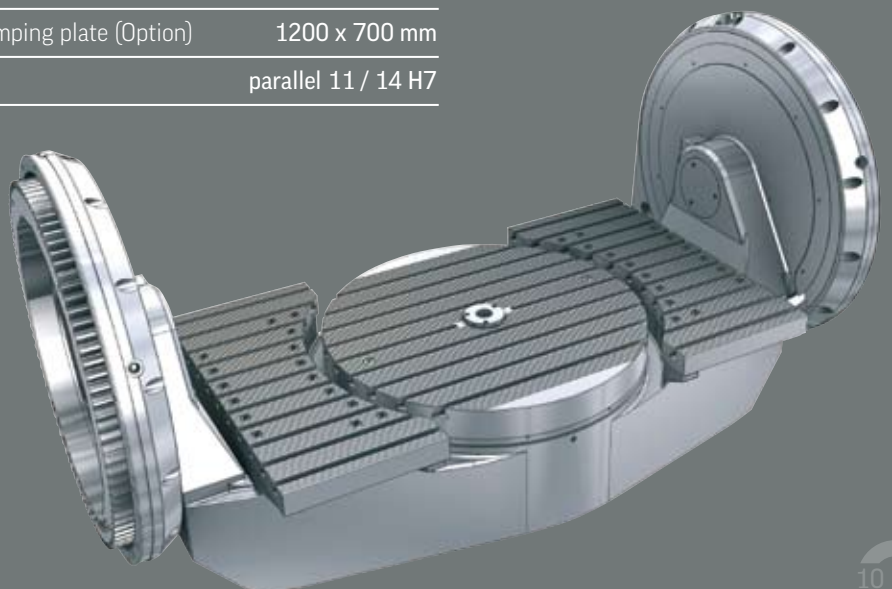

# Spindles

HIGH-TECH SPINDLES FOR DEMANDING MILLING PROCESSES

SLIM-END SPINDLE FOR MACHINING DEEPER CAVITIES

FEW IRREGULAR EDGES (PREVENTION OF COLLISION)

## Spindle

Spindle speed:	9000 rpm.
Interface:	SK 50
Torque:	380 Nm
Main power:	60 kW
Spindle speed:	12000 rpm.
Interface:	HSK A 100
Torque:	380 Nm
Main power:	60 kW

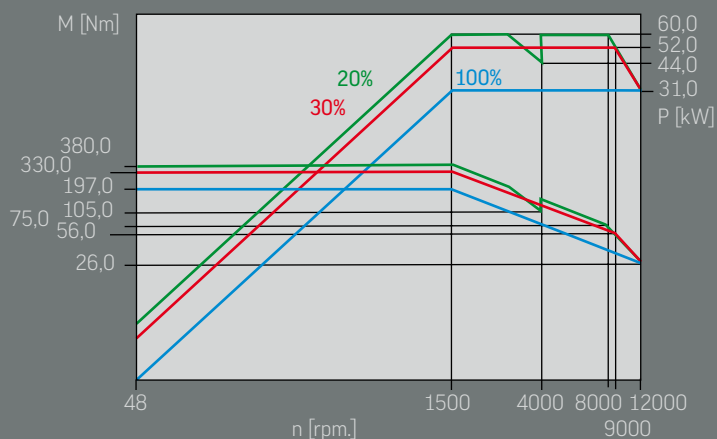

## Spindle

Spindle speed:	18000 rpm.
Interface:	SK 40 / HSK A 63
Torque:	240 Nm
Main power:	39 kW

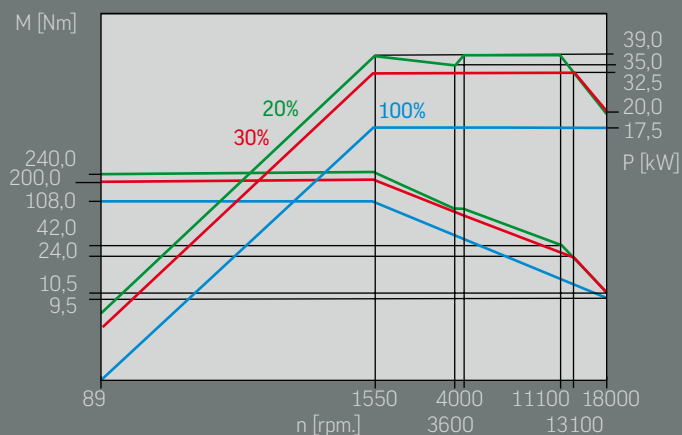

# C 50 UP

PALLET CHANGER PW 2000

TO BE EXTENDED TO A FLEXIBLE MANUFACTURING CELL

TRANSPORT OF COMPLETE MACHINE WITHOUT DISASSEMBLY

WIDE ACCESS DOORS TO THE WORKING AREA

With pallet changer systems in several different sizes, we are setting new standards for setup in parallel to production with our highly dynamic 3-axis, 4-axis, and especially 5-axis machines. Increased productivity through additionally adaptable storage systems.

The pallet changing system PW 2000 was specially designed for the C 50 U dynamic and is able to handle transport weights up to 2000 kg per side including pallet.

The system consists of an NC-controlled traversing unit and a rotary element with double gripper. The generously dimensioned access doors (on the front and side) allow for ergonomic access to the working area and machine setup station for the machine operator. The pallet changing system is shipped without being disassembled and is adapted to the machine.



# Pallet changer

## PW 2000

### Pallet changer PW 2000

Pallet dimensions 800 x 800 / Ø 1000 mm

1000 x 800 / Ø 1166 mm

Number of pallets without storage 2 pallets

Number of pallets with storage 21 pallets

Transport weight per side including pallet  
max. 2000 kg

Repeating accuracy < 0,01 mm

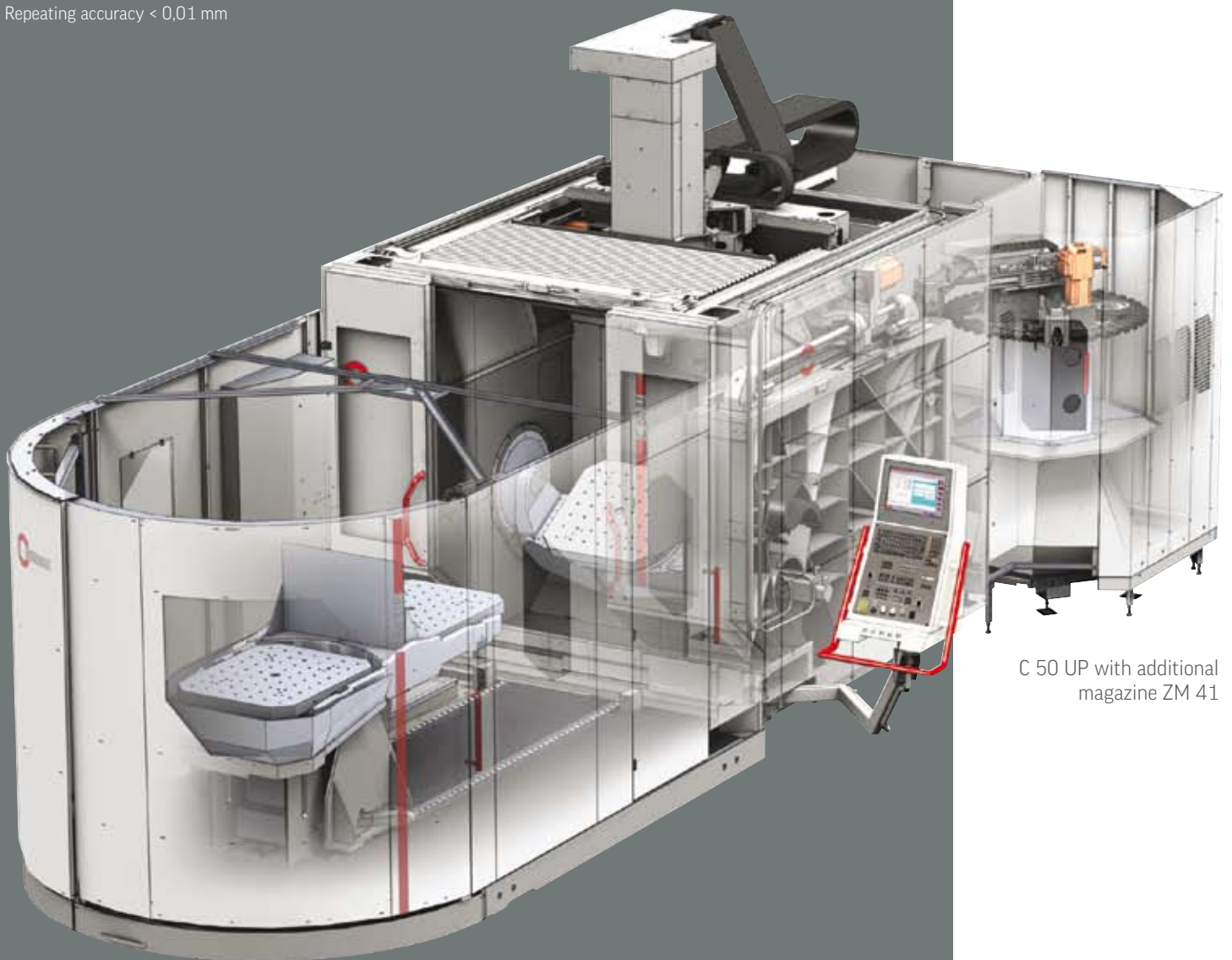

C 50 UP with additional  
magazine ZM 41



# Magazine

PICK UP MAGAZINE

INTEGRATION INTO THE MACHINE BASE (STANDARD MAGAZINE)

VERY GOOD ACCESSIBILITY

COVERS FOR THE SPINDLE TAPERS

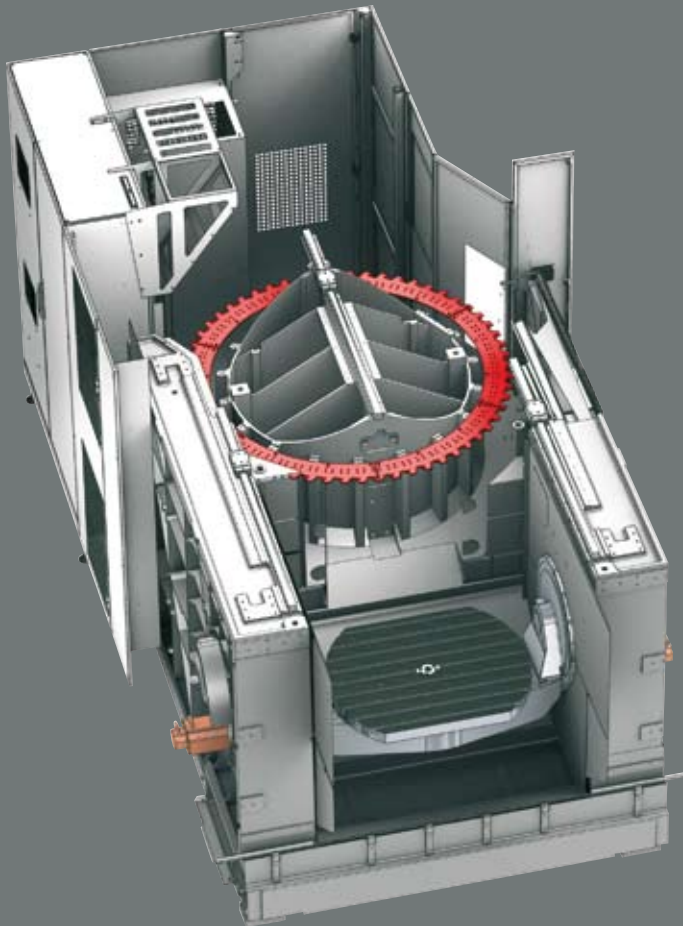

## Tool changer (pick up)

Interface:	SK 40 / HSK A 63	SK 50 / HSK A 100
Chip-to-chip time*:	approx. 7.0 s	approx. 7.0 s
Magazine positions:	60	42
Maximum tool length:	430 mm	430 mm
Maximum tool diameter:	Ø 160 mm	Ø 250 mm
Maximum tool weight:	15 kg	30 kg
Maximum magazine load:	480 kg	462 kg
Additional magazine:	41 pockets	-
Additional magazine:	-	124 pockets
Additional magazine:	162 pockets	-

\* (chip-to-chip time were determined in accordance with VDI 2852, sheet 1 in a 3-axis design)



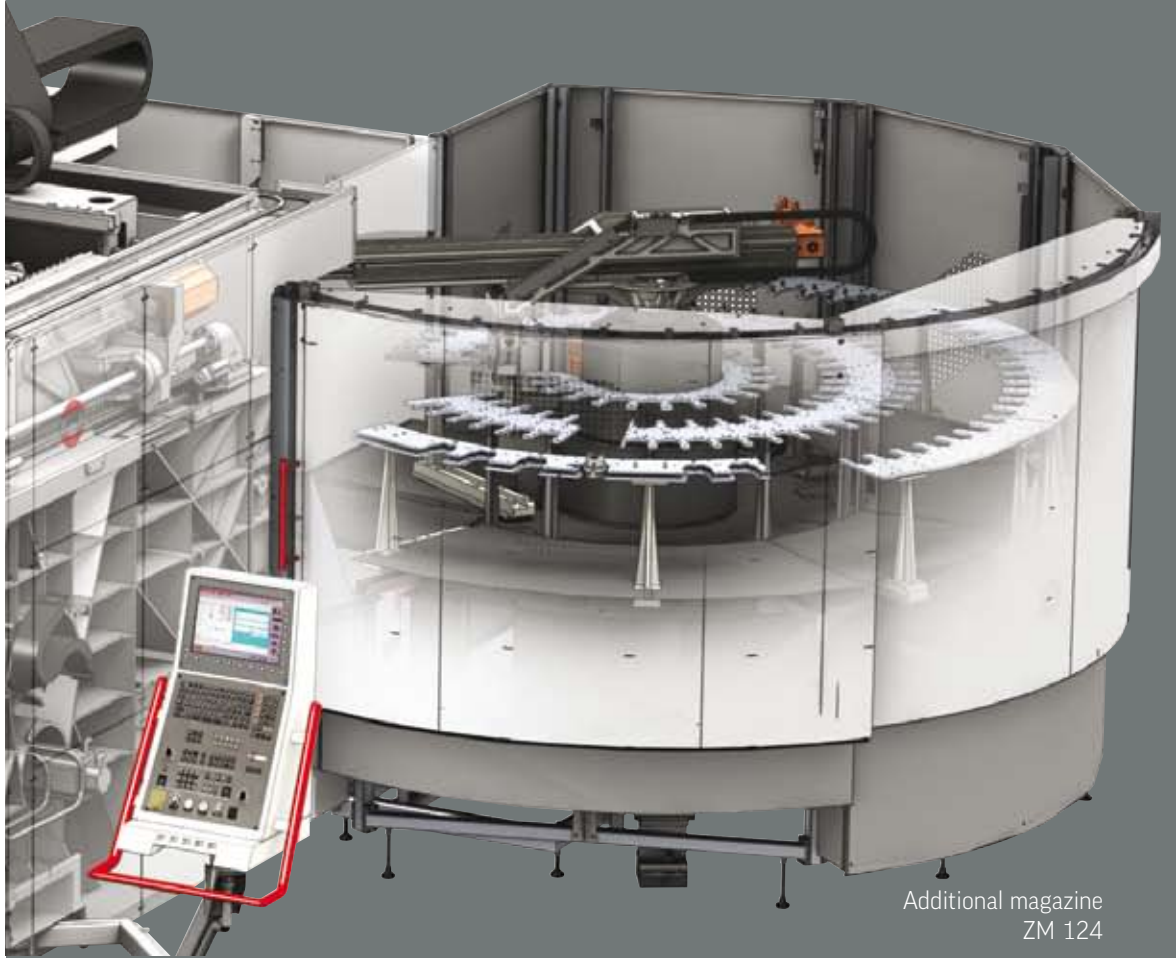

Additional magazine  
ZM 124

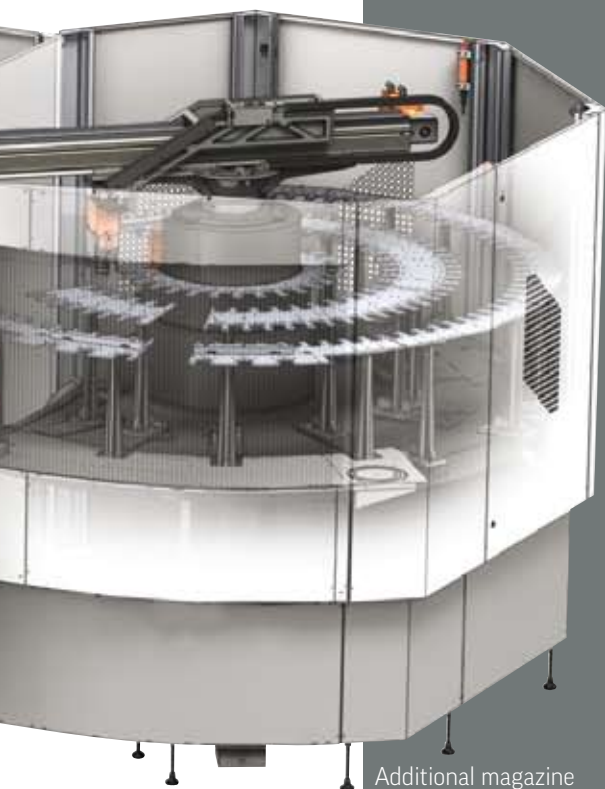

Additional magazine  
ZM 162

#### Additional magazines for complex machining processes

- Own tool management software integrated in the control
- Adapted to magazine loading point
- Up to eight loading points for fast loading of the magazines ZM 124 and 162

# Options

OPTIONS FOR

INCREASING THE SAFETY FEATURES

THE INDIVIDUAL APPLICATION POSSIBILITIES

THE PROCESS SAFETY

THE ECONOMIC EFFICIENCY

## Options in detail

- Through the spindle coolant supply (paper tape filter)
- Minimal quantity lubrication internal + external
- Blowing attachment / bed flushing
- Oil mist extractors
- Tool breakage monitoring system/Tool measurement
- Automatic front doors



# Controls

HEIDENHAIN iTNC 530 OR SIEMENS S 840 D

3D SOFTWARE

15" TFT-TECHNOLOGY

USER-DEFINED SOFTKEYS

smarTNC

ShopMill

## CONTROLS FOR DEMANDING MILLING PROCESSES

Whether for tool and mould making, in production or in high-speed machining, they stand out for their many advantages.

## SAFE CONTROLS

Controls with integrated safety technology keeping with category 3 described in European standard EN 954-1.

## E-MESSENGER

Increases the availability of the machines and minimises production failures.

## TELESERVICE

Teleservice ensures even faster support in case of programming and operating problems.



\* For detailed information, please refer to the individual leaflets.

# Technical data

Working area	Traverse	X axis	1000 mm	
	Traverse	Y axis	1100 mm	
	Traverse	Z axis	750 mm	
	Linear rapid traverse	X axis	60 m/min	
	Linear rapid traverse	Y axis	60 m/min	
	Linear rapid traverse	Z axis	55 m/min	
	Linear acceleration	X-Y-Z	6 m/s <sup>2</sup>	
	Linear feed force	X axis	16000 N	
	Linear feed force	Y axis	16000 N	
Linear feed force	Z axis	16000 N		
Main spindle drive	Speed	18000 rpm.	SK 40 / HSK A 63	■
	Main power/torque	20%ED	39 kW / 240 Nm	
	Speed	12000 rpm.	HSK A 100	●
	Main power/torque	20%ED	60 kW / 380 Nm	
	Speed	9000 rpm.	SK 50	●
	Main power/torque	20%ED	60 kW / 380 Nm	
Control unit	Heidenhain		iTNC 530	■
	Siemens		Sinumerik 840 D	■
Tool changer (pick up)	Interface	SK 40/HSK A 63	SK 50/HSK A 100	●
	Magazine pockets	60	42	
	Chip-to-chip time*	ca. 7.0 s	ca. 7.0 s	
	*(chip-to-chip times were determined in accordance with VDI 2852, sheet 1 in a 3-axis design)			
	Maximum tool length	430 mm	430 mm	
	Maximum tool weight	15 kg	30 kg	
	Maximum tool diameter	Ø 160 mm	Ø 250 mm	
	Maximum magazine load	480 kg	462 kg	
Extension of tool storage capacity	Additional magazine	41 pockets	-	●
	Additional magazine	-	124 pockets	●
	Additional magazine	162 pockets	-	●
Connection values (machine)	Mains connection	400 V / 50 Hz	400 V / 50 Hz	
	Power consumption	71 kVA	84 kVA	
	Compressed air	6 bar	6 bar	
Weight	(standard version)		approx. 21.0 t	
Transport dimensions C 50 (basic machine)	Width		2,930 mm	
	Depth		6,500 mm	
	Height		3,550 mm	

Hermle AG reserves the right to carry out modifications without prior notification, which may lead to deviating technical data.

Table variants	NC-controlled swivelling rotary table	Ø 700 ●	Ø 1150 ●
	Clamping surface	Ø 700 mm	Ø 1150 mm
	Clamping surface 2-sided flattened to	-	900 mm
	Swivel range	+ 100° / - 130°	+ 100° / - 130°
	Speed - swivelling axis A	20 rpm.	20 rpm.
	Speed - rotary axis C	30 rpm.	30 rpm.
	Maximum table load	2,000 kg	2,000 kg
	T-grooves parallel	9 / 14H7	9 / 18H7
	Adjacent clamping plates	1200 x 700 mm	-
	T-grooves parallel	11 / 14 H7	-

Position measuring system direct	Resolution	0.0001 mm	■
----------------------------------	------------	-----------	---

Position tolerance	Tp in X-Y-Z axis keeping with German standard VDI/DGQ 3441 (determined at 20° Celsius +/- 1° Celsius constant ambient temperature. Our products are subject to German export laws and exports have to be approved as the achievable accuracy may be smaller / equal than 6 µm.)	0.008 mm	■
--------------------	--	----------	---

Volume of coolant	Amount of coolant	420 l	■
	Pump delivery	5 bar / 80 L/min	

Through the spindle coolant supply with paper tape filter	Amount of coolant	1,500 l	●
	Pressure (infinitely variable manuel)	max. 80 bar / 26 l/min	
	Mains connection	400 V / 50 Hz	
	Power consumption	26 kVA	

Chip conveyor	Scraper belt conveyor		■
	Hinged belt conveyor		●
	Ejection height of swarf conveyor	1,100 mm	
	Chip cart	450 l	●

Hydraulic system	Operating pressure	120 bar	■
------------------	--------------------	---------	---

Central lubrication system	Minimum quantity lubrication		■
----------------------------	------------------------------	--	---

#### Options

Automatic cabin door	●
Rotating clear-view window	●
Electrical heat compensation	●
Electrical hand-held control module	●
Touch probe including preparation	●
Preparation for touch probe	●
Tool breakage monitoring / measuring system	●
Coolant nozzle	●
Minimal quantity lubrication internal + external	●
Air blast through the spindle centre	●
Bed flushing	●
BDE signal	●
Oil mist extractor	●
Air purge for linear scales	●
Status lamp	●

■ standard equipment

● to order

# Dimensions C 50 U

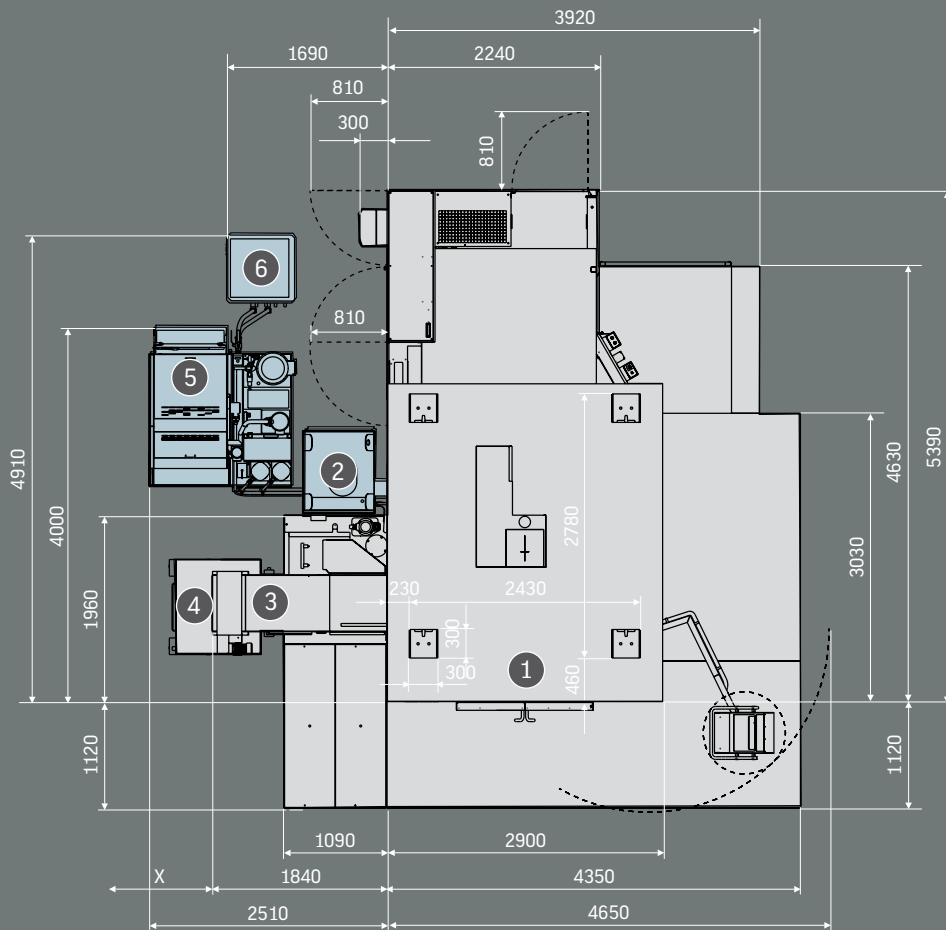
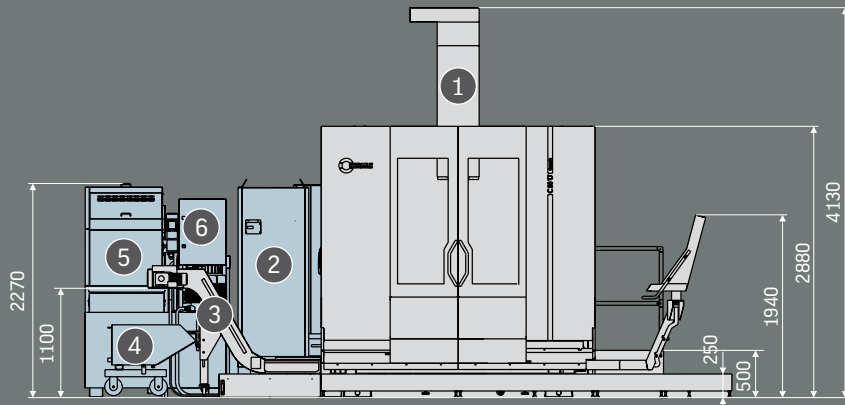

## C 50 U dynamic

- |   |                                    |
|---|------------------------------------|
| 1 | Machine                            |
| 2 | Oil mist extractor                 |
| 3 | Chip conveyor                      |
| 4 | Chip cart                          |
| 5 | Through the spindle coolant supply |
| 6 | continuous-flow cooling unit       |

X Pull-out dimension chip conveyor 2250 mm

# Dimensions C 50 UP

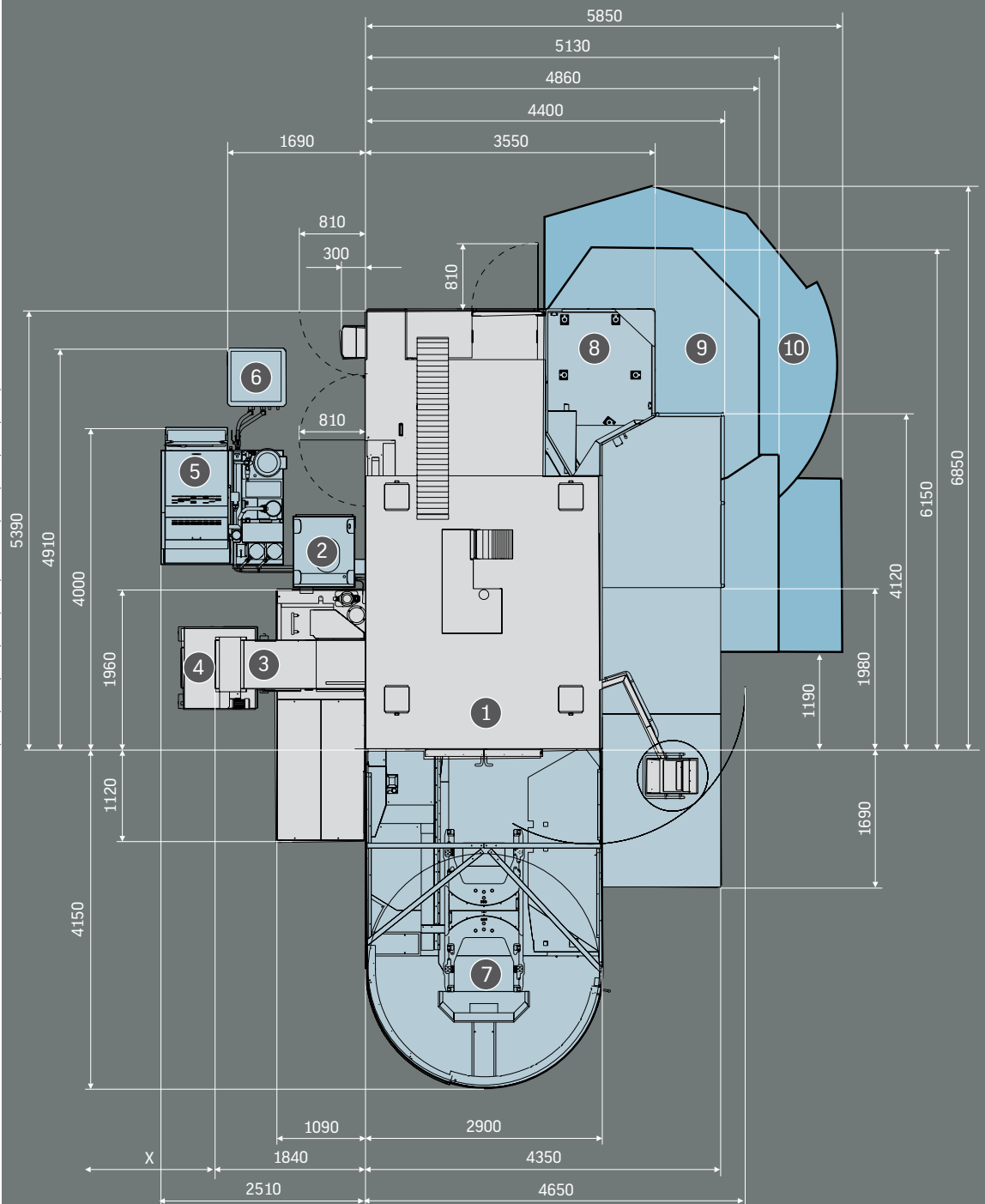
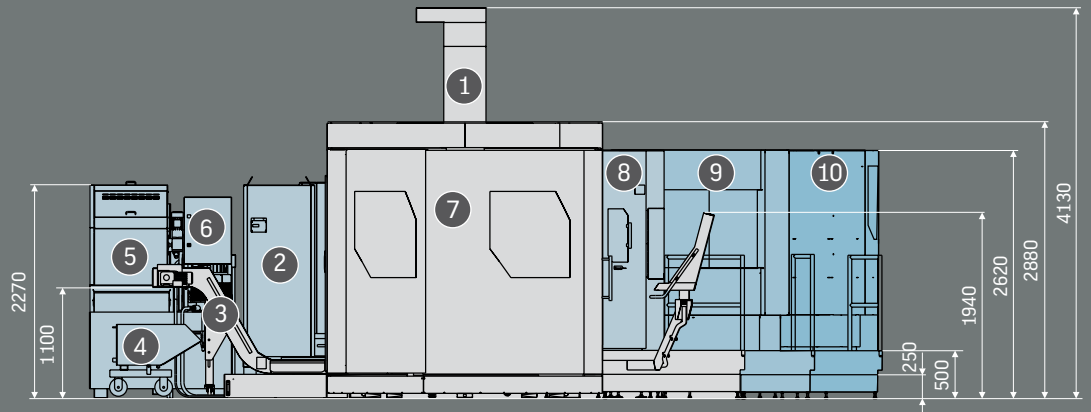

## C 50 UP dynamic

- 1 Machine
- 2 Oil mist extractor
- 3 Chip conveyor
- 4 Chip cart
- 5 Through the spindle coolant supply
- 6 continuous-flow cooling unit
- 7 Pallet changer PW 2000
- 8 Magazine extension ZM 41
- 9 Magazine extension ZM 162
- 10 Magazine extension ZM 124

# Hermle

all over the world

## Hermle + Partner Vertriebs GmbH

Oymühlenstraße 29a - D-87466 Oy-Mittelberg  
Phone +49 (0)8366 988007  
Fax +49 (0)8366 987129  
vertrieb.hpv@t-online.de  
www.hermle-partner-vertrieb.de

## Hermle-Leibinger Systemtechnik GmbH

Daimlerstraße 14 - D-78532 Tuttlingen  
Phone +49 (0)7461 96628-0  
Fax +49 (0)7461 96628-398  
info.hls@hermle.de

## Innovaris GmbH & Co. KG

Daimlerstraße 6 - D-85521 Ottobrunn  
Phone +49 (0)89 6735950-950  
Fax +49 (0)89 6735950-952  
info@innovaris.de  
www.innovaris.de

## Hermle (Schweiz) AG

Tobelackerstrasse 6 - CH-8212 Neuhausen  
Phone +41 (0)52 67400-40  
Fax +41 (0)52 67400-41  
info@hermle-schweiz.ch  
www.hermle-schweiz.ch

## Hermle Nederland B.V.

Moliërelaan 176 - NL-5924 AN Venlo-Blerick  
Phone +31 (0)77 3961761  
Fax +31 (0)77 4641070  
info@hermle-nederland.nl  
www.hermle-nederland.nl

## Verkaufsbüro Belgien

Martin Coun  
Meldertsestraat 55 - B-3545 Halen  
Phone +32 (0)13 5563-83  
Fax +32 (0)13 5563-84  
hermle@scarlet.be

## Hermle Machine Co. LLC

5100 West Franklin Drive  
Franklin, WI 53132, USA  
Phone +1 414 421-9770  
Fax +1 414 421-9771  
info@hermlemachine.com  
www.hermlemachine.com

## Hermle Italia S.r.l.

Via Papa Giovanni XXIII 9-b  
I-20090 Rodano (MI)  
Phone +39 02 95327-241  
Fax +39 02 95327-243  
info@hermle-italia.it  
www.hermle-italia.it

## Hermle Österreich

Rudolf Fluch  
Sportplatzstraße 31/2 - A-8712 Proleb  
Phone +43 (0)3842 83377  
Fax +43 (0)3842 82410  
rudolf.fluch.hpv@utanet.at

## Hermle Česká Republika

Milos Branda  
Chudenická 1060/28  
CZ-102 00 Praha 10  
Mobil +420 731 479 033  
milos.branda.hpv@hermle.cz

## Martin Skukálek

Podhájom 1365/164-73  
SK-01841 Dubnica nad Váhom  
Phone +421 (0)424 441888  
Fax +421 (0)424 441886  
martin.skukalek.hpv@stonline.sk

## Hermle China

Shanghai Representative Office  
Floor 21 E, Shanghai Industry Building No. 18  
North Cao Xi Road  
200030 Shanghai, P.R.China  
Phone +86 21 2281 9188  
Fax +86 21 6427 1887  
hermlesha@126.com

Beijing Representative Office  
No. 1707 Tower A, Dongyu Building  
No. A 1 Shuguang Xili Road  
Chaoyang District  
100028 Beijing, P.R.China  
Phone +86 10 5822 0951/2/3  
Fax +86 10 5822 1426  
hermlebeijing@vip.163.com

## Hermle WWE AG

Zuger Straße 72  
CH-6340 Baar/ZG  
Phone +41 (0)41 768 51-51  
Fax +41 (0)41 768 51-50  
info@hermle-wwe.com

## 000 Hermle Vostok

ul. Polkovaya 1  
RU-127018 Moskau  
Phone +7 495 221 83 68  
Fax +7 495 221 83 93  
info@hermle-vostok.ru

The machining examples used in this leaflet are published with the explicit approval of our friendly customers.

The information in this leaflet only contains general descriptions or performance characteristics which in a real application do not always meet the description or which may change by further development of the products.

The requested performance parameters shall be binding only, if they are explicitly agreed within the sales contract.



Maschinenfabrik  
Berthold Hermle AG  
Industriestrasse 8-12  
D-78559 Gosheim  
Phone +49 (0)7426 95-0  
Fax +49 (0)7426 95-6109  
info@hermle.de  
www.hermle.de